

# **TENDER DOCUMENT**

**For**

**Supply of Voting Compartments  
made of Corrugated Plastic Sheet  
(Flex Board) of Steel Grey Colour  
Duly Printed as per Sample at  
Annexure-‘A’**

**OFFICE OF THE CHIEF ELECTORAL OFFICER, HARYANA  
30-BAYS BUILDING (3<sup>rd</sup> FLOOR), SECTOR 17-B, CHANDIGARH-160017**

**TABLE OF CONTENTS**

Clause No.	Section I - Invitation to Bid	Page No.
1	Instructions and items for Bidding	4
1.2	Scope of work	4-5
2	Schedule of Tender	5
3	Election Department reserves the right to vary quantity	5
4	Election Department reserves right to reject/accept any or all bids	5
5	Period of validity of Bids	6
6	Instructions to Bidders on Electronic Tendering System	6-7
7	Online Payment of Tender Document Fee + Earnest Money	8
8	Terms and Conditions of Tendering Firms	8
9	Bid requirements	9
10	Contents of Bids	9
11	Opening of Bids by Election Department	9-10
	<b>Section II - Tender Terms &amp; Conditions</b>	
12	Work Order	10
13	Inspection	10
14	Penalty Clause	10
15	Payment Terms	11
16	Arbitration Clause	11
17	Jurisdiction of the Civil Court	11
	<b>Section III - Bids Details</b>	
D1	Bidder's Particulars	12-14
D2	Bid Letter	15-17

**OFFICE OF THE CHIEF ELECTORAL OFFICER, HARYANA  
30-BAYS BUILDING (3<sup>rd</sup> FLOOR), SECTOR 17-B, CHANDIGARH-160017**

**IMPORTANT DATES - REGARDING**

**Tender No. 1/1(Tender)/Elec-2019/3AE-**

Starting Date of Tender preparation	06.02.2019
Last Date of EMD submission	19.02.2019 upto 11:00 AM
Last Date of Submission of Tender	21.02.2019 till 1:30 PM
Opening of Tender	(1) At 3:00 P.M. on 21.02.2019 in the O/o the Chief Electoral Officer, Haryana, 30-Bays Building (3 <sup>rd</sup> Floor), Sector 17-B, Chandigarh - 160017. (2) The technical bid will be opened on the above date & time. For opening of financial bid of the bidder whose technical bid is found valid will be intimated lateron.
Tender Fee	Rs. 500/- (Rupees Five Hundred only)
Earnest Money	Rs. 2,00,000/- (Rupees Two Lac only)

**OFFICE OF THE CHIEF ELECTORAL OFFICER, HARYANA  
30-BAYS BUILDING (3<sup>rd</sup> FLOOR), SECTOR 17-B, CHANDIGARH-160017**

**TENDER No. 1/1(Tender)/Elec-2019/3AE-  
SECTION 1: INVITATION TO BID**

**1.1 Instructions & items for Bidding: -**

Bids are invited by the **Chief Electoral Officer**, Haryana from the reputed Firms/Bidders with minimum turnover of Rs.30:00 Lac (Rupees Thirty Lac) per annum for last 3 Years for manufacturing of Corrugated Plastic Sheet (Flex Board) in the box size of 24"x24"x30", 24"x36"x30" and 24"x48"x30" (length x width x height) with multiple folding using 1000 gsm., 5.0 mm thickness, steel grey colour with standing support. Surface of the box will be completely flat able to print.

Approximate quantity is 25000 Voting Compartment in the size of 24"x24"x30" (length x width x height), in the sizes of 24"x36"x30" and in the size of 24"x48"x30" (length x width x height) 8000, 14000 and 3000 in numbers respectively required. All the three sides of the Voting Compartment shall be printed as mentioned at **Annexure-‘A’**.

- 1.1.1 The voting compartment shall be made only of corrugated plastic sheet (Flex Board) of steel grey colour, which is opaque and reusable.
- 1.1.2 Bidders have to submit technical and financial bid separately clearly indicating technical & financial bids on the top of envelopes addressed to The Chief Electoral Officer, Haryana alongwith their complete address at the bottom.

**1.2 Scope of Work: -**

- A) In order to maintain secrecy of vote at the time of poll and uniformity on use of voting compartments, the Election Commission has prescribed some specifications on the type of voting compartment which can be used at the polling stations. The voting compartments are to be made only of corrugated plastic sheets (flex board) of steel grey colour, which is opaque and reusable. Time is the essence of this contract and bidders may ensure that they process adequate infrastructure and capabilities before submitting their bids. Bidders should be able to supply the required goods within the time scheduled specified at centralized store situated in Court Complex, Ambala City, Haryana.
- B) Corrugated Plastic Sheet (Flex Board) of 1000 gsm., 5.0 mm thick size with the provision of handling.

**OFFICE OF THE CHIEF ELECTORAL OFFICER, HARYANA  
30-BAYS BUILDING (3<sup>rd</sup> FLOOR), SECTOR 17-B, CHANDIGARH-160017**

- C) All the three sides of the Voting Compartment shall be printed as mentioned in the appended **Annexure-‘A’**
- D) The competent authority shall be at liberty to allot work of supply of Voting Compartment to any of the bidders at the approved (L/1) rates if the circumstances so warranted. The allottee shall be required to deposit an amount equal to EMD in case the same has been refunded to him.

**2. Schedule of Tender**

- 2.1 The sealed bids (technical & financial bid) would be accepted till 1.30 P.M. on 21.02.2019
- 2.2 The technical bid will be opened at 03:00 P.M on 21.02.2019 in the O/o the Chief Electoral Officer, Haryana, 30-Bays Building (3<sup>rd</sup> Floor), Sector 17-B, Chandigarh – 160017 in the presence of bidders or their authorized representatives who elect to be present and financial bid of the bidders whose technical bid is found valid, opening date will be conveyed separately.
- 2.3 The address for all the above activities is:  
O/o Chief Electoral Officer, Haryana  
30 Bays Building, Top Floor, Sector 17-B, Chandigarh – 160017.

**3. The Chief Electoral Officer, Haryana reserves the right to vary quantities.**

The Chief Electoral Officer, Haryana further reserves the right to issue supply order of manufacturing of voting compartments among the selected Bidders /party(s). Work preference can also be extended to the firms/ industries located in Haryana as per Govt. policy letter dated 28.05.2010.

**4. Right to accept or to reject.**

- 4.1 The Chief Electoral Officer, Haryana reserves the right to accept or reject any or all bids without assigning any reason.
- 4.2 The officers/officials of the Chief Electoral Officer, Haryana and the District Election Officer would at any point of time, be free to visit the premises where the job is being executed to ensure that the processes are followed as specified in the tender. If any default is detected during inspection or otherwise, the allotment of work to the tenderer shall be liable to be withdrawn. The tenderer shall be liable to imposition of suitable penalty upon him also.
- 4.3 The Chief Electoral Officer, Haryana reserves the right to allow the work to one party or to distribute the work to the parties as the circumstances demand at the time of allotment of work keeping in view urgency and

**OFFICE OF THE CHIEF ELECTORAL OFFICER, HARYANA  
30-BAYS BUILDING (3<sup>rd</sup> FLOOR), SECTOR 17-B, CHANDIGARH-160017**

interest of the work as well as capacity of the firm and therefore, the bidders other than L/1 would be required to give their consent to the L/1 rates within specified time and their security would be retained and they would be given work but the highest single portion would be given to L/1 bidder.

**5. Period of Validity of Bids**

Bids will remain valid upto 31.10.2019. A bid valid for a shorter period would be rejected.

**6. Instructions to Bidders on Electronic Tendering System**

**These conditions will over-rule the conditions stated in the tender documents, wherever relevant and applicable.**

**6.1 Registration of bidders on e-Procurement Portal:-**

All the bidders intending to participate in the tender process online are required to get registered on the centralized e-Procurement Portal i.e. <https://haryanaeprocurement.gov.in>. Please visit the website for more details.

**6.2 Obtaining a Digital Certificate:**

**6.2.1** The Bids submitted online should be encrypted and signed electronically with a Digital Certificate to establish the identity of the bidder bidding online. These Digital Certificates are issued by an Approved Certifying Authority, by the Controller of Certifying Authorities, Government of India.

**6.2.2** A Digital Certificate is issued upon receipt of mandatory identity (i.e. Applicant's PAN Card) and Address proofs and verification form duly attested by the Bank Manager / Post Master / Gazetted Officer. Only upon the receipt of the required documents, a digital certificate can be issued. For more details please visit the website – <https://haryanaeprocurement.gov.in>.

**6. 2.3** The bidders may obtain Class-II or III digital signature certificate from any Certifying Authority or Sub-certifying Authority authorized by the Controller of Certifying Authorities or may obtain information and application format and documents required for the issue of digital certificate from.

**6.2.4** The bidder must ensure that he/she comply by the online available important guidelines at the portal <https://haryanaeprocurement.gov.in> for Digital Signature Certificate (DSC) including the e-Token carrying DSCs.

**6.2.5** Bid for a particular tender must be submitted online using the digital certificate (Encryption & Signing), which is used to encrypt and sign the data during the stage of bid preparation. In case, during the process of a particular tender, the user loses his digital certificate (due to virus attack, hardware problem, operating system or any other problem) he will not be able to submit the bid online. Hence, the users are advised

**OFFICE OF THE CHIEF ELECTORAL OFFICER, HARYANA**  
**30-BAYS BUILDING (3<sup>rd</sup> FLOOR), SECTOR 17-B, CHANDIGARH-160017**

**to keep a backup of the certificate** and also keep the copies at safe place under proper security (for its use in case of emergencies).

**6.2.6** In case of online tendering, if the digital certificate issued to the authorized user of a firm is used for signing and submitting a bid, it will be considered equivalent to a no-objection certificate /power of attorney / lawful authorization to that User. The firm has to authorize a specific individual through an authorization certificate signed by all partners to use the digital certificate as per Indian Information Technology Act 2000. Unless the certificates are revoked, it will be assumed to represent adequate authority of the user to bid on behalf of the firm in the department tenders as per Information Technology Act 2000. The digital signature of this authorized user will be binding on the firm.

**6.2.7** In case of any change in the authorization, it shall be the responsibility of management / partners of the firm to inform the certifying authority about the change and to obtain the digital signatures of the new person / user on behalf of the firm / company. The procedure for application of a digital certificate however will remain the same for the new user.

**6.2.8** The same procedure holds true for the authorized users in a private/Public limited company. In this case, the authorization certificate will have to be signed by the directors of the company.

**6.3 Pre-requisites for online bidding:**

In order to operate on the electronic tender management system, a user's machine is required to be set up. A help file on system setup/Pre-requisite can be obtained from Nextenders (India) Pvt. Ltd. or downloaded from the home page of the website - <https://haryanaeprocurement.gov.in>. The link for downloading required java applet & DC setup are also available on the Home page of the e-tendering Portal.

**6.4 Online Viewing of Detailed Notice Inviting Tenders:**

The bidders can view the detailed N.I.T and the time schedule (Key Dates) for all the tenders floated through the single portal eProcurement system on the Home Page at <https://haryanaeprocurement.gov.in>.

**6.5 Download of Tender Documents:**

The tender documents can be downloaded from the e-Procurement portal & <https://haryanaeprocurement.gov.in>

**6.6 Key Dates:**

The bidders are strictly advised to follow dates and times as indicated in the online Notice Inviting Tenders. The date and time shall be binding on all bidders. All online activities are time tracked and the system enforces time locks that ensure that no activity or transaction can take place outside the start and end dates and the time of the stage as defined in the online Notice Inviting Tenders.

**OFFICE OF THE CHIEF ELECTORAL OFFICER, HARYANA**  
**30-BAYS BUILDING (3<sup>rd</sup> FLOOR), SECTOR 17-B, CHANDIGARH-160017**

**7. Online Payment of Tender Document Fee + Earnest Money:**

- 7.1 The tender document fee Rs. 500/- (Rs. Five Hundred only) and Earnest Money Rs. 2.00 Lac (Rs. Two Lac only) can be made using the secure electronic payment gateway. The Payment for Tender Document Fee shall be made by bidders/Vendors online directly through Internet Banking Accounts. The Payment for EMD shall be made online directly through RTGS/NEFT. The secure electronic payments gateway is an online interface between contractors and Debit card / online payment authorization networks.
- 7.2 The Chief Electoral Officer, Haryana would retain the Earnest Money Deposited for a maximum period of One year from the date of opening of the bid till the deposit of the security amount by the firm to whom the work has been allotted.
- 7.3 No interest would be payable by the Chief Electoral Officer, Haryana on the Earnest Money deposited by Bidder.
- 7.4 Earnest money is liable to be forfeited at any time if, it is found that the tenderer had, with malafide intention, tried to cheat or otherwise misrepresent to the Department.
- 7.5 The EMD is liable to be forfeited if the Bidder withdraws or amend, impairs or derogates from the tender in any respect within the period of validity of the Tender.
- 7.6 If the successful Bidder fails to furnish the security deposit as required in the contract within the specified period, the Earnest Money would be liable to be forfeited by the Department.
- 7.7 The order can be divided amongst more than one consenting firms at L/1 rate because of paucity of time-depending upon their capacities but in any case highest single order shall be given to L/1. In such eventuality the EMD of all consenting firms shall be retained.
- 7.8 The EMD of the unsuccessful Bidders would be returned by the Election Department as early as possible after the expiry of validity of their bids, but not later than 45 days. Bidders are advised to send a pre-receipt in the prescribed format given at the bottom of **Annexure-D1** along with their bids to facilitate refund of earnest money in time.

**8. Terms and Conditions of Tendering firms**

The Bidder should submit their bids in the format given in the Tender Document only. Printed terms and conditions of the bidder in any other format would not be considered. Technical and financial bid is to be submitted separately.



**OFFICE OF THE CHIEF ELECTORAL OFFICER, HARYANA  
30-BAYS BUILDING (3<sup>rd</sup> FLOOR), SECTOR 17-B, CHANDIGARH-160017**

**9. Bid Requirements**

- A) The Bidder must quote their rate for the complete job i.e. manufacturing of voting compartment with corrugated Plastic Sheet (Flex Board) of 1000 gsm., 5.0 mm thickness duly printed as per sample mentioned in the appended **Annexure-‘A’**.
- 9.1 The successful Bidder would be required to furnish Security Deposit amounting to Rs. 5:00 lac with the office of the Chief Electoral Officer, Haryana.
- 9.2 The Bid Documents are not transferable and the cost of the tender document is not refundable under any circumstances.
- 9.3 Bids sent through telex/e-mail/ fax will be rejected. Incomplete bids will also be rejected.
- B) Bidders should enclose alongwith the bid of their offers, the full details of corrugated plastic sheet (Flex Board) to be used with specifications in D1.
- 9.4 The bidder shall state that they had never been black listed by any State/Central Govt. departments/Boards/ Corporations etc.

**9. Contents of Bid**

The Bids prepared by the Bidder would comprise of the following components/ documents to be filled as per the formats provided in the Tender Document

- i) Earnest Money.
- ii) Bidders Particulars (Annexure-D1) alongwith supporting documents duly sealed & addressed to the Chief Electoral Officer, Haryana in hard form also by 21.2.2019 upto 13:00 hrs.
- iii) Fee Rs.500/- of Tender Documents.
- iv) Bid Letter (Annexure-D2)

1<sup>st</sup> Envelope shall be opened first and all the details & eligibility shall be checked first and in case of ineligibility or non-filing of crucial information, the offer in Envelope II shall be rejected without opening and decision in this regard shall be binding and no further query/correspondence shall be entertained.

**10. Opening of Bids by Election Department**

The Election Department Haryana would open the bids in the presence of Bidders/representatives who choose to attend on the date and time as mentioned at Clause 2.4 at the Office of Chief Electoral Officer, Haryana, 30 Bays Building, Sector 17-B, Chandigarh. The bidder's representative who are present would sign a register evidencing their attendance. The Bidder's

**1<sup>st</sup>  
Envelope  
Technical  
Bid**

**2<sup>nd</sup>  
Envelope  
Financial  
Bid**

**OFFICE OF THE CHIEF ELECTORAL OFFICER, HARYANA  
30-BAYS BUILDING (3<sup>rd</sup> FLOOR), SECTOR 17-B, CHANDIGARH-160017**

representative would furnish letter of authority from its principal to attend the opening of the bid.

**SECTION II – TENDER TERMS AND CONDITIONS**

**11. Work Order**

- 11.1 The work order shall be placed by the O/o Chief Electoral Officer, Haryana directly to the allottee.
- 11.2 The work shall be done by the allottee as per the Terms and Conditions contained in this Tender Document and shall deliver the voting compartments to the Election Tehsildar & In-charge, Election Store, Court Complex, Ambala City.
- 11.3 The Bidder is required to do the job to the satisfaction of Chief Electoral Officer, Haryana. In case of any fault detected, the party would rectify the fault free of cost. In the eventuality of the work got done from other source, it would be got done at the risk and cost of the party whose failure in executing the work has led to the situation.

**12. Inspection**

Inspection would be carried-out by a committee consisting the specialty officer(s) to ensure that the quality of material and other parameters of the job assigned are being met. The firm would render all assistance to the inspecting committee for smooth conduct of inspection.

**13. Penalty clause:**

The Complete Job/order will have to be executed within 20 days from the date of issue of work order, failing which penalty for late execution of the order would be levied on the amount payable as follow:-

- a) For delay up to one week (07 days) 1% per week of the value of the order remaining balance for execution.
- b) For delay more than one week to three weeks 3% per week of the value of the balance order. For delay of more than three weeks EMD and security would be forfeited and no payment would be made for work done.
- c) The Chief Electoral Officer, Haryana shall also be entitled to get the remaining work done at the risk and cost of the bidder/firm.

**OFFICE OF THE CHIEF ELECTORAL OFFICER, HARYANA  
30-BAYS BUILDING (3<sup>rd</sup> FLOOR), SECTOR 17-B, CHANDIGARH-160017**

**14. Payment Terms**

- a) The payment shall be released by this office within reasonable period after receipt and verification of the work done.
- b) No bill will be entertained, unless it is submitted in triplicate and accompanied by acknowledgement/delivery vouchers etc.

**15. Arbitration Clause:**

All disputes arising out of this contract would be referred to sole arbitrator i.e. Commission and Secretary, Elections Department, Haryana or an officer appointed by the Govt. of Haryana whose decision would be final and binding upon both parties.

**16. Jurisdiction of the civil Court.**

All disputes would be settled at Chandigarh. The Courts at Chandigarh would only have the jurisdiction to entertain and adjudicate upon any dispute arising out of the terms and conditions of the tender.

**OFFICE OF THE CHIEF ELECTORAL OFFICER, HARYANA  
30-BAYS BUILDING (3<sup>rd</sup> FLOOR), SECTOR 17-B, CHANDIGARH-160017**

**Annexure- D1**

**BIDDER'S PARTICULARS**

**(to be given in separate envelope I with EMD as this would be examined before opening the bid and the gaps would be required to be filled in advance)**

(BIDDERS SHOULD FURNISH ANSWERS TO ALL THE QUESTIONS BELOW. BIDDERS MAY PLEASE NOTE THAT IF THE ANSWERS SO FURNISHED ARE NOT CLEAR AND/OR ARE EVASIVE, THE ENTRY WOULD BE LIABLE TO BE IGNORED.)

**1. Business name and Constitution of the firm.**

1.1 Name of Office:	
1.2 Full address of office	
1.3 Full address of work place of your firm	
1.4 No. of Branches:	
1.5 Nature of Business:	
1.6 Telephone Nos. (O): Mobile No.:	
<b>1.7 Income Tax PAN No:</b>	
1.8 Sales Tax No. /or GST No.	
<b>(2) Turnover in the last three financial years duly verified by the CA:</b> (Please attach copies of audited operating A/cs)	2015-16, Rs. _____ 2016-17, Rs. _____ 2017-18, Rs. _____

**3. Bank details**

Bank Name:	
Branch:	
Bank Account No:	
Type of Bank Account:	
Name of Account holder:	

4. Is the firm registered? If yes, under which Act:

**OFFICE OF THE CHIEF ELECTORAL OFFICER, HARYANA  
30-BAYS BUILDING (3<sup>rd</sup> FLOOR), SECTOR 17-B, CHANDIGARH-160017**

- (a) The Indian Companies Act, 1956 (b) The Indian Partnership Act, 1932 (Please also give name of partners) (c) Any other Act.
5. Name of the owners / promoters / partners (Please give full names and address).
6. For Partnership firms state whether registered or not registered under the Indian Partnership Act, 1932. please state:-
- (a) Whether by the Partnership agreement, authority to sign the tender document and to refer disputes concerning the business of the partnership to arbitration has been conferred on the partner(s) who has signed the tender.
- (b) If the answer to (a) is in the negative, whether there is any general power of attorney executed by all the partners of the firm authorizing the partners who signed the tender to sign and to refer dispute concerning business of the partnership to arbitration.
- (c) If the answer to either (a) or (b) is in the affirmative furnish a copy of either the partnership agreement or the general power of attorney as the case may be.
- (d) Names, Addresses etc. of Partners/Members/Directors (For information about more persons, please add separate sheet(s) in the format given below):

(i) Details of Partners/ Members/ Directors:	
(ii) No. of Partners/ Members/ Directors:	
(iii) Full Name:	
(iv) Name of Premises/Building/Village (with full address):	
(v) Date of Incorporation/ Agreement/ Partnership:	
(vi) If premises located outside of Haryana State then write the	

**OFFICE OF THE CHIEF ELECTORAL OFFICER, HARYANA  
30-BAYS BUILDING (3<sup>rd</sup> FLOOR), SECTOR 17-B, CHANDIGARH-160017**

distance in Km. from the border of Haryana:	
(vii) Income Tax PAN No.	
(viii) Sales Tax No. / or GST No. etc.	

**N.B.**

- (1) Please attach to the tender a copy of the document on which reliance is placed for authority of partner or the partner(s) to sign the tender and to refer disputes to arbitration. The copy should be attested by a Notary Public or its execution should be admitted by Affidavit on a stamped paper by all the partners.
  - (2) Where authority to sign the tender document and to refer disputes to arbitration has not been given to the partner(s) signing the tender the tenders must be signed by every partner of the firm.
7. Have you/ the firm ever been blacklisted by any Govt. Department/ office? If yes, please give details. If no, please mention 'No' specifically.
8. I/We have read all the instructions carefully and undertake to abide by the same.

Signature of Witness:  
Full name & address of  
Witness in Block letters

Signature of Bidder

(1) Full name and address of the persons  
Signing (In BLOCK letters)

(2) Whether signing as Proprietor/Partner  
Constituted Attorney/duly authorized  
by the Company.  
(seal)

Date:

**OFFICE OF THE CHIEF ELECTORAL OFFICER, HARYANA  
30-BAYS BUILDING (3<sup>rd</sup> FLOOR), SECTOR 17-B, CHANDIGARH-160017**

**Annexure-D2**

**BID LETTER**  
**(To be given in sealed Envelope)**

To

Chief Electoral Officer, Haryana  
30 Bays Building, Sector 17-B,  
Chandigarh.

**Subject: Tender for Supply of Voting Compartments with Corrugated Plastic Sheet (Flex Board) of Steel Grey Colour, dully printed.**

Sir,

We declare:

- 1.1 I/We hereby offer to supply Voting Compartment manufactured Corrugated Plastic Sheet (Flex Board) as per the specification at **Annexure-‘A’** of the Election Commission of India in sizes of 24”x24”x30”, 24”x36”x30” and 24”x48”x30” (length x width x height) with multiple folding using 1000 gsm, 5.0 mm thickness, colour steel grey with standing support. Surface of the box will be completely flat surface able to print.

S. No.	Size of Voting Compartment	Quantity	Rate to be Quoted by the Firm per Pc
1	24”x24”x30”	8000Pcs	
2	24”x36”x30”	14000Pcs	
3	24”x48”x30”	3000Pcs	

The above rates are inclusive of F.O.R. delivery at the Election Store, Court Complex, Ambala City.

2. Period of Delivery: I/We do hereby undertake that in the event of acceptance of my/our bid, the job order would be completed within the stipulated period. The delivery of the manufactured voting compartment shall be delivered to the Election Store, Ambala City.

**OFFICE OF THE CHIEF ELECTORAL OFFICER, HARYANA  
30-BAYS BUILDING (3<sup>rd</sup> FLOOR), SECTOR 17-B, CHANDIGARH-160017**

3. I/We agree to abide by this bid that it will be valid upto 31.10.2019 from the date of receipt of work allotment order.
4. We hereby certify that we have read and understood the terms and conditions of the tender and the conditions of the Contract applicable to the tender and we do hereby undertake to supply as per these terms and conditions.
5. Certified that the Bidder is:  
A sole proprietorship firm and the person signing the tender is the sole proprietor/constituted attorney of the sole proprietor.

**Or**

A partnership firm, and the person signing the tender is a partner of the firm and he has authority to refer to arbitration disputes concerning the business of the partnership by virtue of the partnership agreement/by virtue of general power of attorney.

**Or**

A company and the person signing the tender is the constituted attorney.

6. I/We undertake, if my/our bid is accepted, to commence the work immediately on receipt of the work order and to complete the job specified in the Contract within the stipulated period calculated from the date of receipt of the work order. If my/our bid is accepted we would submit a fixed deposit/DD from a Scheduled Bank for an amount of Rs. 5:00 Lac (Rupees Five Lac only).
7. I/We understand that you are not bound to accept the lowest or any bid you may receive. We also understand that you have the right to vary the quantities and/or split the total order among the Bidders as mentioned in the tender document.

**NOTE:- Delete whatever is not applicable. All corrections/deletions should invariably be duly attested by the person authorized to sign the tender document.**



**OFFICE OF THE CHIEF ELECTORAL OFFICER, HARYANA  
30-BAYS BUILDING (3<sup>rd</sup> FLOOR), SECTOR 17-B, CHANDIGARH-160017**

Dated: this \_\_\_\_\_ day of \_\_\_\_\_ 2019 Signature of Bidder

Details of enclosures

Full Name: \_\_\_\_\_

Full address: \_\_\_\_\_

\_\_\_\_\_

\_\_\_\_\_

Telephone No. \_\_\_\_\_

E-mail: \_\_\_\_\_

Fax No. \_\_\_\_\_

**Annexure - A**

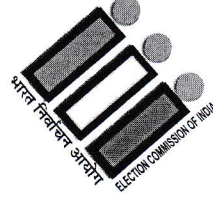

**भारत निर्वाचन आयोग  
मतदान कम्पार्टमेंट**

**ELECTION COMMISSION OF INDIA  
VOTING COMPARTMENT**

**ON ONE SIDE - FACING THE WEB CAMERA**

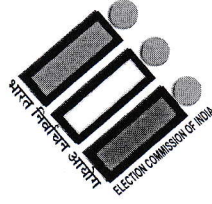

**Name of State/UT:**

**AC/PC Name:**

**AC/PC Number:**

**Date of Poll:**

**Polling Station Name:**

**Polling Station Number:**

Annexure-B

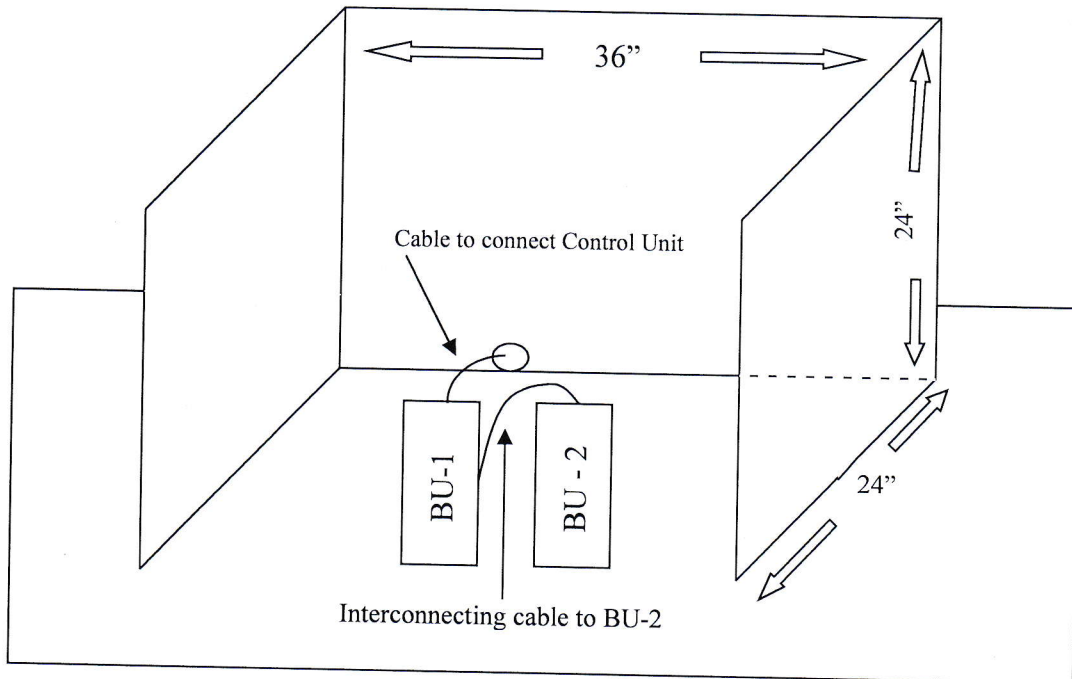
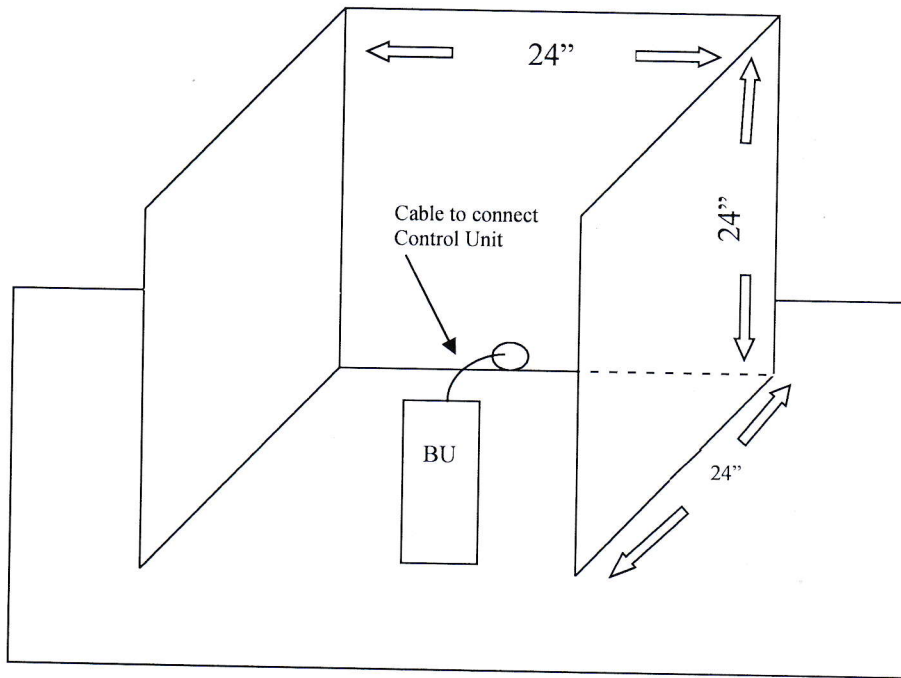

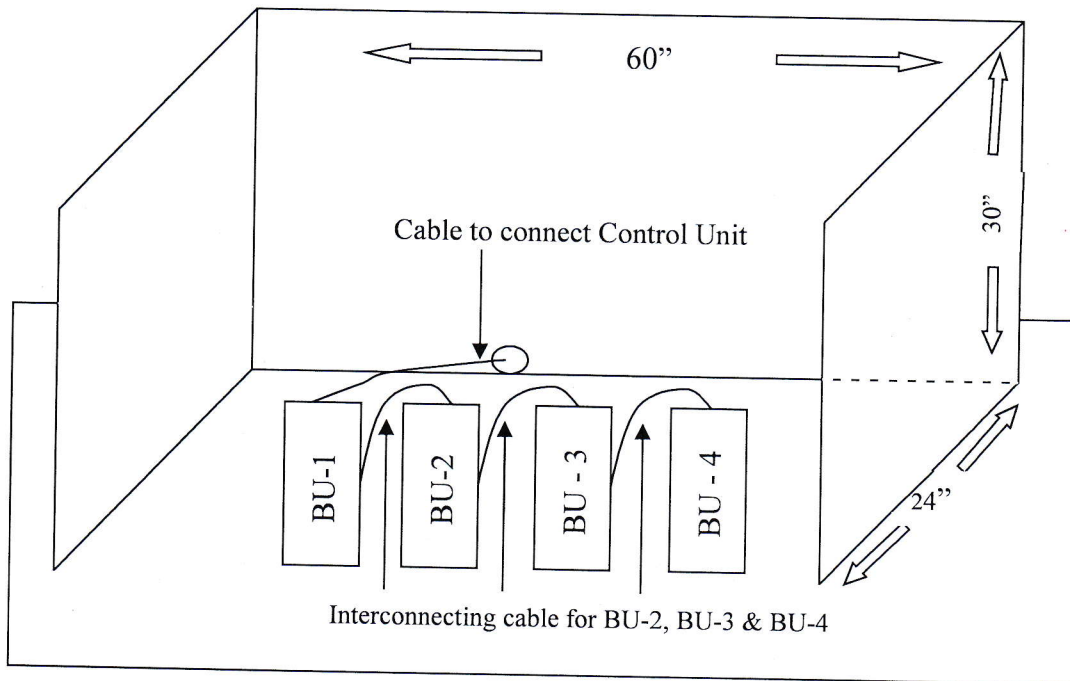
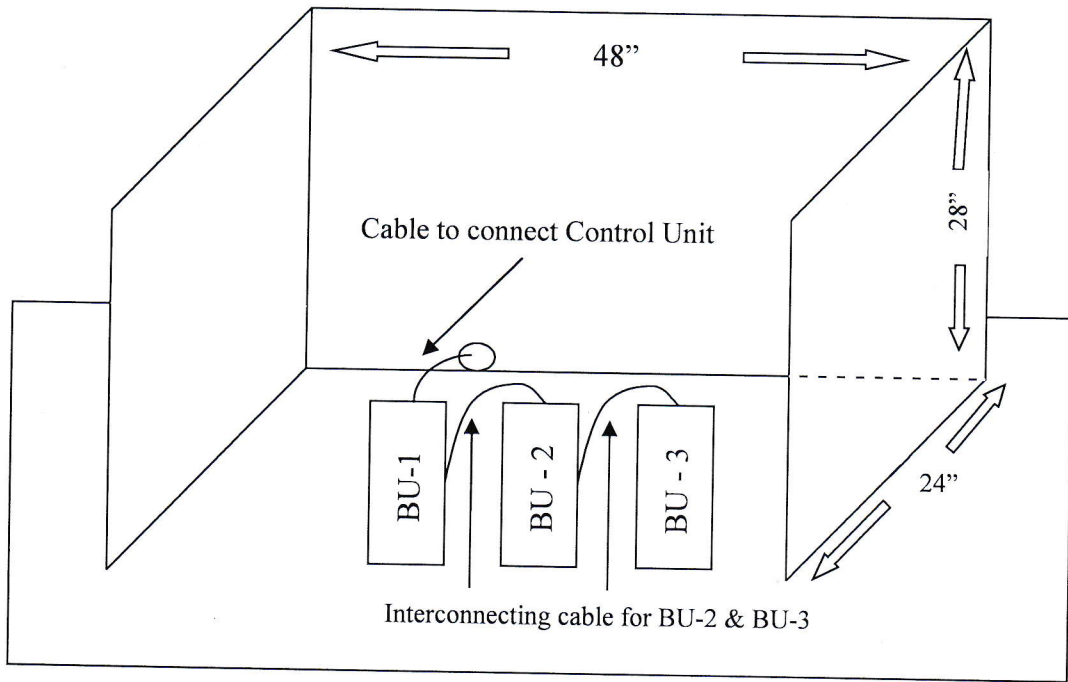

Annexure-C

